



FITTING INSTRUCTIONS FOR

Side Mirror Antenna Mount

SKU

KS0815

COMPATIBILITY

Toyota Prado 150

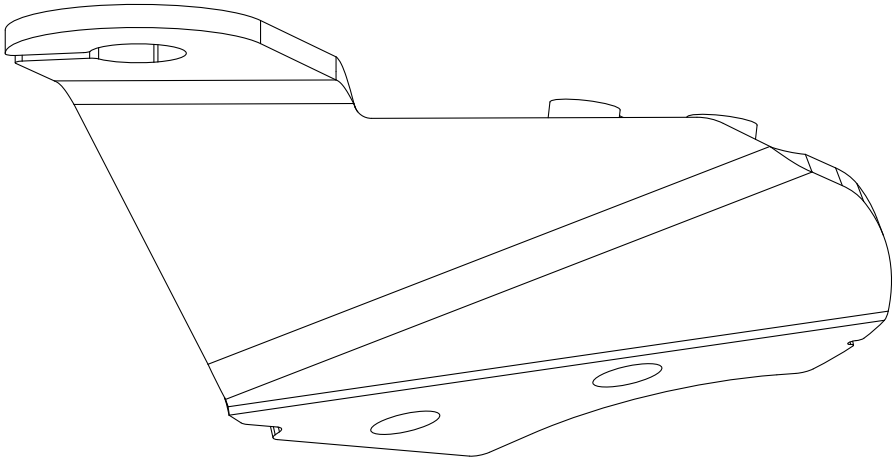

Included contents

QTY	COMPONENT
1	Antenna Mount Bracket
1	Antenna Mount Body
2	M6 x 16 Countersunk Socket Head Screw
3	M5 x 40 Socket Head Cap Screw
2	Small Cable Tie



Time

1 hour / One beer

Also required (not included)

Electrical Tape

Scan the **QR code** to watch the video installation guide,
or for further information contact KAON on **07 3180 1470** or info@kaon.com.au



Bolt Torque

DIAMETER (mm)	5mm	6mm	8mm	10mm	12mm
NEWTON-METRES (Nm)	5 Nm	9 Nm	22 Nm	44 Nm	77 Nm

Let's get to work.

Preparing the Vehicle

1. There are two ways to install this antenna mount. The option we recommend is to remove the mirror and route the antenna cabling through the door panel into the cabin. This will create the cleanest installation of the antenna, and will be covered in these instructions.

A simpler but less concealed method is to install the bracket to the mirror without removing it from the vehicle, and then run the cable through the grommets in the A-pillar. If installing this way, ensure that tape is applied underneath the mirror to protect the vehicle's paint.

2. Remove the interior door trim with a trim tool by lifting and prying the trim panel away at the edge of the door.
3. Remove the small panel backing of the interior handle, exposing the factory screw. Unscrew and set aside.
4. Next, remove the handle's trim with a trim tool. Unscrew the remaining two factory screws holding the door trim in place, and set aside.
5. Disconnect the power window control and the plug running the cable to the mirror.



Preparing the Vehicle cont.

6. To save time, instead of unplugging all the components attached to the trim, we recommend resting the trim in an elevated spot against the door for the remainder of the install.
7. Remove the interior mirror trim using a trim tool.
8. Unbolt the three factory M10 bolts holding the mirror by loosening and removing the nuts holding them in place. Ensure that you support the mirror during this process, to prevent it falling.
9. Remove the mirror from the vehicle. There is a clip holding it in place so it may require a light bit of force.



Preparing the Vehicle's Mirror

10. Use a trim tool to remove the trim at the base of the mirror.
11. Remove the three factory bolts surrounding the mirror's cable.

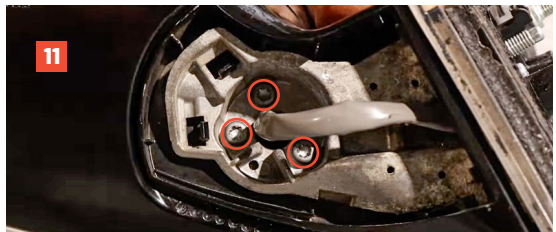

Installing the Antenna Mount Body

12. Run the antenna cable through the same opening that the mirror's cable routes through in to the door. It may be easier to pull back through some of the mirror cable first, to help feed the antenna cable through simultaneously. Pull through about three quarters of the antenna cable's length.
13. Pull a little of the mirror cable back through and push aside, so that the space is free to install the Antenna Mount Body.
14. Place the Antenna Mount Body in the socket, as pictured, so that the bolt holes align. Secure using the three provided M5 bolts.
15. Tighten the M5 bolts to the recommended torque settings.



Installing the Antenna Mount Bracket

16. Place the Antenna Mount Bracket over the Antenna Mount Body in the orientation pictured.
17. Bolt to the mirror using the provided M6 bolts, and tighten until secure.

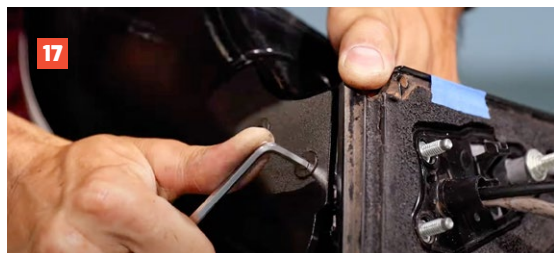

Mounting the Antenna

18. Place the antenna through the slotted opening in the bracket.
19. Secure the antenna base by threading on the nut.
20. Tighten the nut until secure and pull through the antenna cable to remove excess wire.



Reattaching the Mirror

21. Thread the cables back through the opening in to the door to the interior of the vehicle.
22. Attach the mirror to its original position. Secure again using the factory M6 nuts, and tighten.

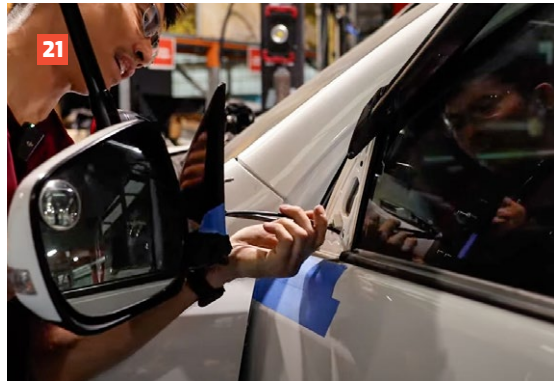

Running the Antenna Cable

23. Remove the trim under the glove box by unbolting the factory bolt and pulling downwards. Set aside.
24. Remove the left trim panel under the glove box by turning the plastic nut on the vehicle's floor anticlockwise, and set it aside.
25. Remove the two factory M6 bolts on either side of the grommet on the inside edge of the vehicle's door, and loosen the rubber seal so that it does not block access.
26. Unclip the metal bracket holding the wire loom to the grommet.
27. Next, undo the factory tape securing the wires, to create more space around the opening of the grommet.
28. Thread the antenna cable through the opening in the grommet, guiding the cable until it reaches the interior of the vehicle and can be pulled through.
29. Now you can route your cable!
We'll leave that part up to you, as it will depend on where you want your radio.

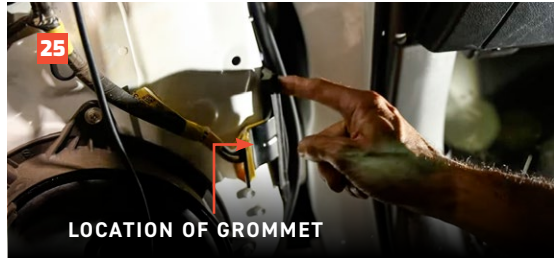
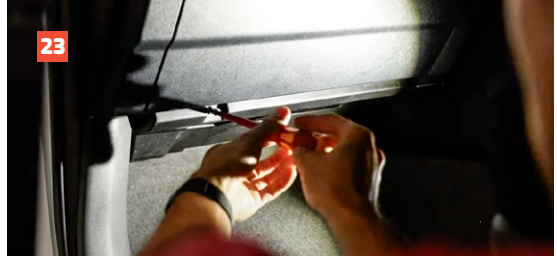

Finishing the Install

30. Now that the antenna cable is installed, secure it to the wire loom running through the grommet with electrical tape.
31. Clip the metal bracket back in place on the grommet to hold the wire loom securely.
32. Reinstall the grommet using the two factory M6 bolts and then reattach the door's seal.
33. Reattach the mirror's power cable to the plug in the door, ensuring that any slack from the mirror has been pulled through.
34. Secure the antenna cable to the wire loom in the door panel with the two small cable ties provided. Trim the ends of each cable tie.
35. Reattach all trim under the vehicle's glove box.
36. Now is the time to re-install the door trim. Start by reconnecting the power windows control.
37. Align the four tabs at the top of the door's interior with the top of the door trim. Click each tab into place, and push on the edges of the trim to ensure that it is in securely in place.
38. Reinstall all the door's interior trim, reversing the order we removed them earlier.

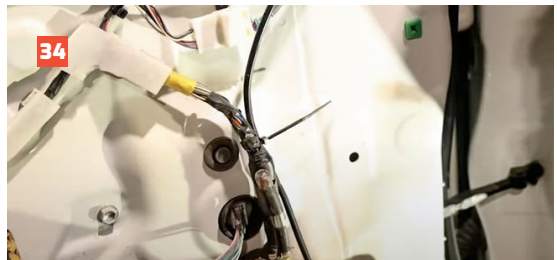

Finishing the Install cont.

39. Finally, reattach the trim on the mirror's interior side.
40. Confirm the position of the antenna and cable and adjust if necessary. Ensure the antenna is tightened until secure.
41. That's it, you're done!
All that's left to do is to hit the road, and enjoy the uninterrupted view from your windscreen.



Local Knowledge & Assistance

We know half the fun of building your dream 4x4 is getting your hands dirty. But we also know that sometimes, things don't go to plan. If in the pursuit to build the ultimate setup you find yourself off-track, we're here to help you get unstuck.

For further information call 07 3180 1470 or email info@kaon.com.au

Disclaimer: The products sold by KAON should not be modified, and are for use only on the vehicles specifically stated. KAON will not be liable for any damages arising out of the use or misuse of its products. It is the customer's responsibility to ensure the products are safely and properly used and installed. KAON consistently seeks to improve its products and reserves the right to make changes to any product.