



FITTING INSTRUCTIONS FOR

# Electric Handbrake Guard

SKU

**KS0852**

COMPATIBILITY

**Toyota LandCruiser LC300**

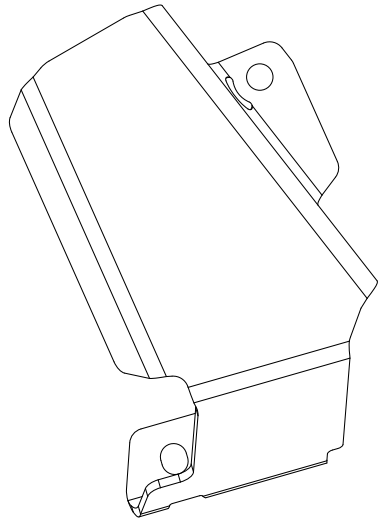
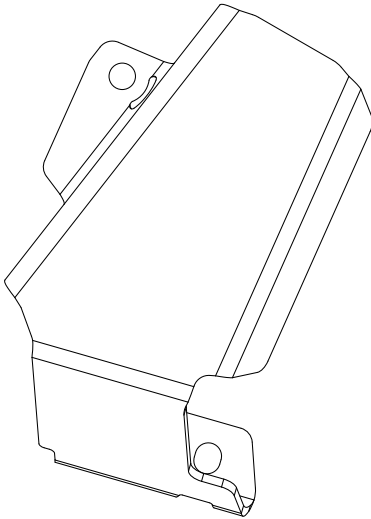

## Included contents

QTY	COMPONENT
1	Electric Handbrake Guard LHS
1	Electric Handbrake Guard RHS
2	M10 x 30 x 2.5 DIN Flat Washer
4	M8 x 16 Socket Head Cap Screw
4	M8 x 17 x 1.2 Washer



**Time**

5 minutes / Few sips of beer

Scan the **QR code** to watch the video installation guide,  
or for further information contact KAON on **07 3180 1470** or [info@kaon.com.au](mailto:info@kaon.com.au)



## Bolt Torque

DIAMETER (mm)	5mm	6mm	8mm	10mm	12mm
NEWTON-METRES (Nm)	5 Nm	9 Nm	22 Nm	44 Nm	77 Nm

# Let's get to work.

---

## Installation

1. We want a nice clean starting surface, so remove any dirt and debris from the mounting surfaces.
2. Place the guard in place over the electric handbrake.
3. Loosely secure the top mount using an M8 bolt and washer.
4. On the bottom mount, slide the M10 washer underneath the guard and against the electric handbrake to act as a spacer. Secure in place using the other M8 bolt and washer.



---

## Installation cont.

5. Using an allen key, tighten the bolts to the recommended torque settings.
6. Repeat steps 1-5 on the other side of the vehicle with the other guard.
7. That's it, you're done!  
All that's left to do is hit the road.





## **Local Knowledge & Assistance**

We know half the fun of building your dream 4x4 is getting your hands dirty. But we also know that sometimes, things don't go to plan. If in the pursuit to build the ultimate setup you find yourself off-track, we're here to help you get unstuck.

**For further information call 07 3180 1470 or email [info@kaon.com.au](mailto:info@kaon.com.au)**

Disclaimer: The products sold by KAON should not be modified, and are for use only on the vehicles specifically stated. KAON will not be liable for any damages arising out of the use or misuse of its products. It is the customers responsibility to ensure the products are safely and properly used and installed. KAON consistently seeks to improve its products and reserves the right to make changes to any product.